

# Extendible Tail Hoist

EX Series



A WASTE BUILT COMPANY

- Provides operators the option of loading in areas with low overhead clearance
- Inside controls standard reducing the chance of driver injury
- Durable rear hinge designed to withstand the stress of grueling day after day use



## The Galfab Advantage



### Outboard Supported Side Rollers

Greasable roller shaft is removable with two bolts.



### Low Loading Angle

An 80" tail provides a low loading angle.



### Optional Side Roller on Tail

Tail reduces stress on the long sills of the container.



### Optional Wings on Tail

Tail is great for loading misaligned containers.

## Standard Features

- 8 x 4 x 1/2" Tube Main Frame
- 3 x 2 x 1/4" Tube Sub Frame
- 2 1/2" Diameter Rear Hinge
- All Working Points Greasable
- 1" Spring Loaded Container Locks
- 2 1/2" Diameter Lift Cylinder Shafts
- 10" Diameter Cable Sheaves
- 52 Gallon Oil Reservoir
- Suction Screen and Return Filter
- Inside and Outside Controls
- Sealed Lighting System

## Options

- Behind Cab and Oversize Oil Tanks
- Tool Boxes
- Auxiliary Stops
- Poly or Steel Fenders
- Tarping Systems
- Hooker Hold On Systems
- Ratchet Tie Down Straps
- Pintle Hook
- Front Mount Pump
- PTO
- Drop Shaft

DISTRIBUTED BY:

# Extendible Tail Hoist

EX Series

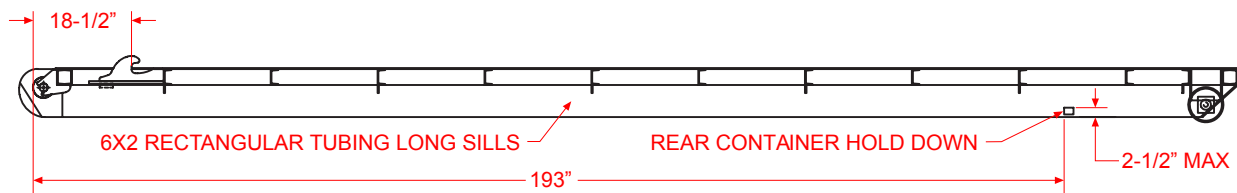
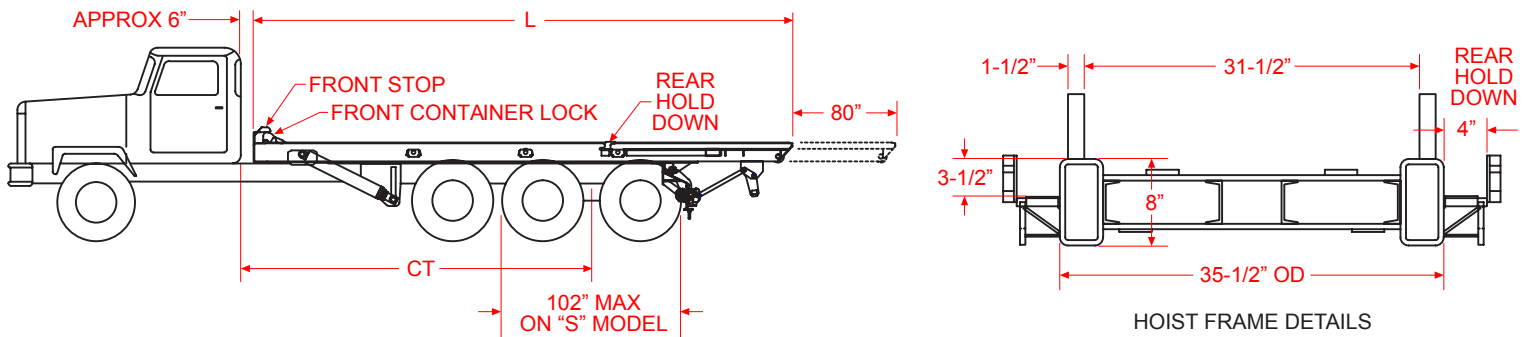

OUTSIDE RAIL CONTAINER REQUIREMENTS

Model	Rated Cap.	CT	L	Dump Angle	Up (Sec.)*	Down (Sec.)*	On (Sec.)*	Off (Sec.)*	Lift Cylinder	Winch Cylinder	Container Length	Appx. Wgt.
EX 60174 S074.5	60,000#	174"	19' 10"	48 deg.	30	13	46	37	6" - 4 1/2" x 74 1/2" DA	7" x 3" x 81 1/2" DA	18' to 22'	8000#
EX 60174 T121	60,000#	174"	19' 10"	48 deg.	43	10	46	37	6" - 5" - 4" x 121" DAT	7" x 3" x 81 1/2" DA	18' to 22'	8000#
EX 60194 T121	60,000#	194"	21' 5"	48 deg.	43	10	51	42	6" - 5" - 4" x 121" DAT	7" x 3" x 91 1/2" DA	20' to 24'	8900#
EX 60194 T083	60,000#	194"	21' 5"	48 deg.	30	13	46	37	6" - 5" x 83" DAT	7" x 3" x 91 1/2" DA	20' to 24'	8050#
EX 60194 T114	60,000#	194"	21' 5"	48 deg.	43	10	46	37	6" - 4" x 114" DAT	7" x 3" x 91 1/2" DA	20' to 24'	8875#
EX 60229 T138	60,000#	229"	28' 5"	46 deg.	60	24	72	59	6" - 5" - 4" x 138" DAT	7" x 3" x 91 1/2" DA	24' to 28'	9775#

\* Cycle Times are Factory developed and controlled by PTO output, oil viscosity, human and mechanical efficiency, and may vary accordingly.

All dimensions are subject to steel and manufacturing tolerances.

CAUTION: This Equipment Should be Operated by Properly Trained Personnel. Improper Use, Misuse or Lack of Maintenance Could Cause Injury to Persons or Property. Photos used in this brochure are illustrative only. We reserve the right to make changes at any time without notice. Information contained within this literature is believed to be the most accurate available at the time of printing.

## Optional Features



Optional Tool Box



Optional Pintle Hitch

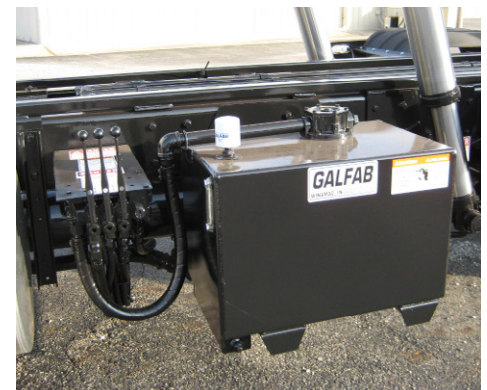

3 Spool Valve with Mounting Bracket

Version 5.2.13