

# Single Axle Hook Hoist

H1 Series



A WASTE BUILT COMPANY

- Driver can load and unload from cab, reducing the chance of injury
- Short wheel base enables it to fit in tight areas
- No cable to hook or unhook means less time spent per pull and more potential pulls per day
- Able to load containers that are not aligned perfectly with the hoist
- Up to a 60 degree dump angle



## The Galfab Advantage



### Hook Access

Hook location allow driver to pick up containers lower than the level of the truck.



### Hook Design

No cables mean faster cycle times and a safer driver.



### Rear Flange Rollers

Rollers allow even off center containers to be picked up and hauled.



### Inside Controls

Controls increase driver safety and production.

### Standard Features

- Outside Reservoir
- Outside Controls
- Hydraulic Pump
- Hoist Up and Back Up Alarms
- Sealed Lighting System
- All working Points Greaseable

### Options

- Behind Cab Tank
- Front Mount Pump
- PTO
- Tool Boxes
- Poly or Steel Fenders
- Inside Controls
- Pintle Hook

DISTRIBUTED BY:

# Single Axle Hook Hoist

H1 Series



A WASTE BUILT COMPANY

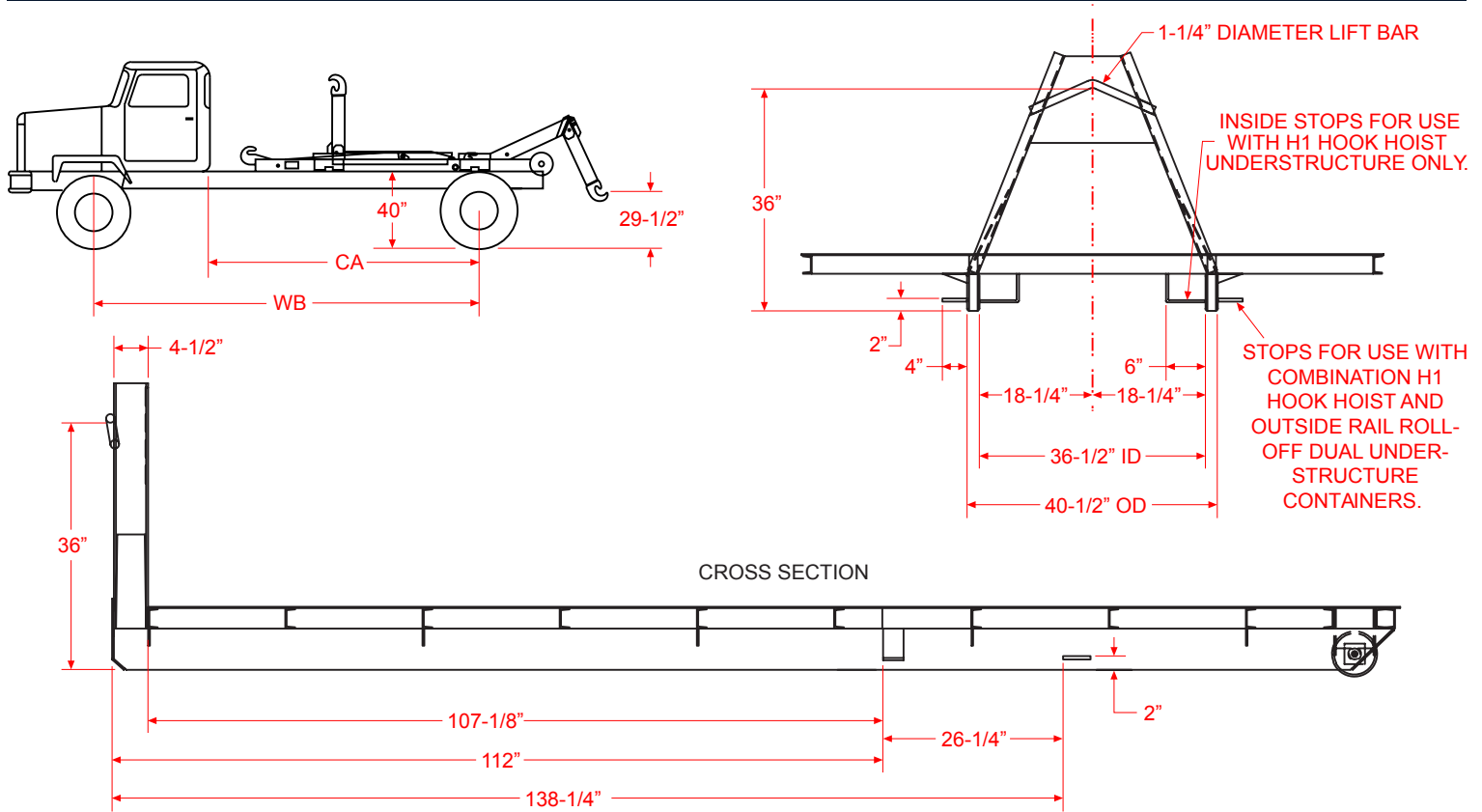

Model	Rated Cap.	Type	CA	Bail Height	Hoist Length	Recommended Container Length
H1-130-3420	20,000#	Hooklift	130"	34"	153"	12' - 14'
H1-130-3620	20,000#	Hooklift	130"	36"	153"	12' - 14'
H1-144-3620	20,000#	Hooklift	144"	36"	167"	13' - 15'

CAUTION: This Equipment Should be Operated by Properly Trained Personnel. Improper Use, Misuse or Lack of Maintenance Could Cause Injury to Persons or Property. Photos used in this brochure are illustrative only. We reserve the right to make changes at any time without notice. Information contained within this literature is believed to be the most accurate available at the time of printing.

## Additional Features



Outside Controls and Reservoir



Poly Fenders



Steel Fenders with Tarp System Option

Version 5.2.13