

# ACCU-PAK VERTICAL COMPACTORS

## D-400, D-600 & D-800

**Designed for restaurants, motels, grocery stores, apartment complexes or other places where installation space is limited.**

The Accu-Pak is the industry's largest, fastest, and strongest vertical compactor. Versatile patented 4-1 head design is the only vertical compactor in the industry that can be changed to front, rear, left or right feed in the field. Powerful 5 horsepower motor is larger than competing models and increases equipment life cycle. Fast 20 second cycle time increases productivity and is up to 50% more efficient than competing models.



Available in 3, 4, 6 or 8 yard front load containers.



### Value Added Benefits

<b>Improved efficiency</b>	<ul style="list-style-type: none"><li>• Quicker cycle times improve employee efficiency; trash is compacted in just 20 seconds</li></ul>
<b>Increased performance</b>	<ul style="list-style-type: none"><li>• 18" of ram penetration and over 28,000 lbs. of ram force ensure maximum compaction</li></ul>
<b>Standard features included at no additional charge</b>	<ul style="list-style-type: none"><li>• Patented 4-1 head can be changed to feed from front, rear, left side or right side</li><li>• Full Container Light alerts you when trash is ready for pickup</li><li>• Magnetic interlock prevents the compactor from operating if door is open or container is not properly in place</li><li>• Low temperature oil feature works well in hot or cold climates*</li><li>• Driver light is illuminated when it is safe for the hauler to remove the container</li><li>• Built-in container stop prevents the container from "walking" during compaction</li></ul>
<b>Ease of ownership</b>	<ul style="list-style-type: none"><li>• Purchase, rental and leasing programs available</li></ul>
<b>Warranty</b>	<ul style="list-style-type: none"><li>• 3-1-1 warranty is a 3 year structural, 1 year parts and 1 year labor warranty</li></ul>

\* Use of an oil heater is recommended in extreme cold conditions.



Tel: 877.468.9278  
sales@wastequip.com  
www.wastequip.com



# ACCU-PAK VERTICAL COMPACTORS

## D-400, D-600 & D-800

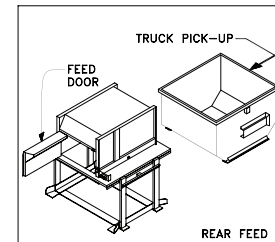
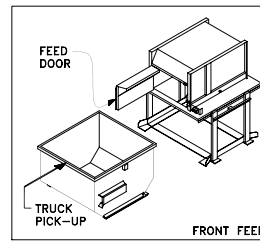
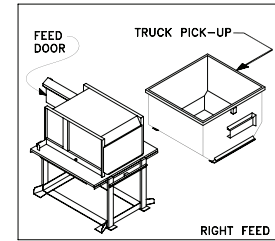
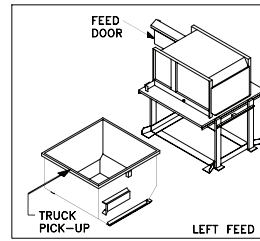
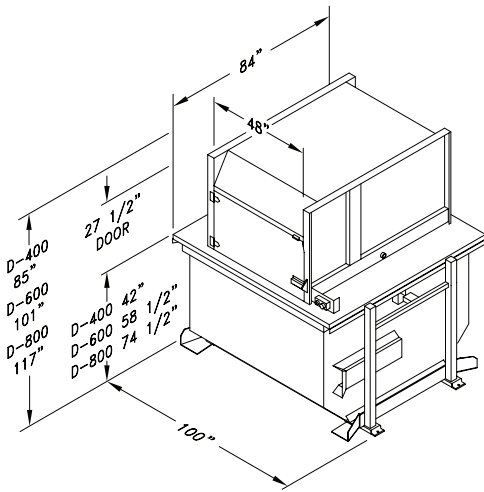

### Standard

- 20 second cycle time
- Full container light
- Low temperature oil
- Operational and service manual
- Primed and painted in several colors

### Options

- Chute extension
- Loading platform with safety rail
- Through the wall installation
- Thermostat oil controlled heater
- Automatic odor suppression system
- Biodegradable oil
- Single phase 220 volt or 110 volt available

### Specifications

		D-400*	D-600	D-800*
Charge Box	Wastequip rating		0.5 cu. yds.	
	Wastec rating		0.42 cu. yds.	
	Compactor weight with stand and container	3,540 lbs.	3,740 lbs.	3,940 lbs.
Ram	Ram height		36"	
	Ram penetration		18.00"	
	Face plate		7 gauge, 48"W x 36"H	
	Base plate		7 gauge, 47 1/2"W x 36"H	
	Side plates		7 gauge, 36"W x 19 11/16"H	
Compactor Head	Sides		11 gauge, (2) 83 1/2"W x 19"H	
	Top deck		11 gauge, (2) 83 1/2"W x 21"H	
Electrical	Electric motor, fan cooled		5 hp	
	Voltage		208/230/460, 3 phase 60 Hz	
	Power box		UL rated, TEFC housing	
	Automated cycle operation		Turn key switch-ram extends, retracts & stops automatically	
Hydraulic Performance	Pump		4.7 gpm	
	Pump type		Gear	
	Hydraulic oil tank		7 gallon reservoir	
	Cylinder bore/rod/stroke		4" bore, 2" rod, 16" stroke	
	Normal ram face pressure		28,300 psi	
	Maximum ram face pressure		31,400 psi	
	Normal ram psi		2,250	
	Maximum ram psi		2,500	
	Cubic yard per hour		76 cu. yd./hr.	
	Power unit location		Internal	
Cycle time		20 seconds		

\* Specifications are the same as the D-600, except where indicated.

**PARTS PLACE** Replacement parts available online at [www.partsplace-inc.com](http://www.partsplace-inc.com)



### Standard Color Choices\*



\* Colors shown are as accurate as printing allows. The actual color is subject to variation from the printed color sample. Color choices vary by plant location. Please contact your local sales representative for available colors. Custom colors are available upon request and are subject to an additional charge.



Wastequip is the leading North American manufacturer of waste and recycling equipment for collecting, processing and transporting recyclables and solid or liquid waste.

August 2010 © Wastequip, all rights reserved. Specifications subject to improvement without notice. Equipment displayed should be operated by properly trained personnel. Operators should become familiar with OSHA, ANSI and any other applicable standards or laws for using this equipment. Improper use, misuse, or lack of maintenance could cause injury to people and/or property. Photos used in the literature are illustrative only. We assume no liability or responsibility for proper training/operation of equipment not manufactured by Wastequip. We reserve the right to make changes at any time without notice. Information contained within this literature is intended to be the most accurate available at time of printing.