

# Inside/Outside Rail Hoist

IO Series



A WASTE BUILT COMPANY

- The most versatile hoist in the market
- Combines Outside Rail and Dempster Dino pickups in one hoist package.
- Heavy duty 1/2" thick mainframe
- Inside controls standard reducing the chance of driver injury
- 48 degree dump angle on all models
- Durable rear hinge designed to withstand the stress of grueling day after day use
- 2 minute loading cycle time\* keeping your drivers on the road
- Available in 60k and 75k pound models to fit any application.



## The Galfab Advantage



### Auto Fold Bumper

Bumper folds forward reducing the chance of bending and hang-ups in the landfill.



### Outboard Supported Side Rollers

Rollers are bolted to the side of the frame, allowing for easier replacement and better support of the container.



### Container Support Rails

Rails aid in loading misaligned containers and give added support to the long sills increasing the life of your container.



### Cor-Ten Divider Angle

Cor-Ten Divider Angle made from heavy duty steel to ensure it will last.

## Standard Features

- 8 x 4 x 1/2" Tube Main Frame
- 3 x 2 x 1/4" Tube Sub Frame
- 2 1/2" Diameter Rear Hinge
- All Working Points Greasable
- 1" Spring Loaded Container Locks
- 2 1/2" Diameter Lift Cylinder Shafts
- 10" Diameter Cable Sheaves
- 52 Gallon Oil Reservoir
- Suction Screen and Return Filter
- Inside and Outside Controls
- Sealed Lighting System

## Options

- Behind Cab and Oversize Oil Tanks
- Tool Boxes
- Auxiliary Stops
- Poly or Steel Fenders
- Tarping Systems
- Hooker Hold On Systems
- Ratchet Tie Down Straps
- Pintle Hook
- Front Mount Pump
- PTO
- Drop Shaft

DISTRIBUTED BY:

# Inside/Outside Rail Hoist

IO Series



A WASTE BUILT COMPANY

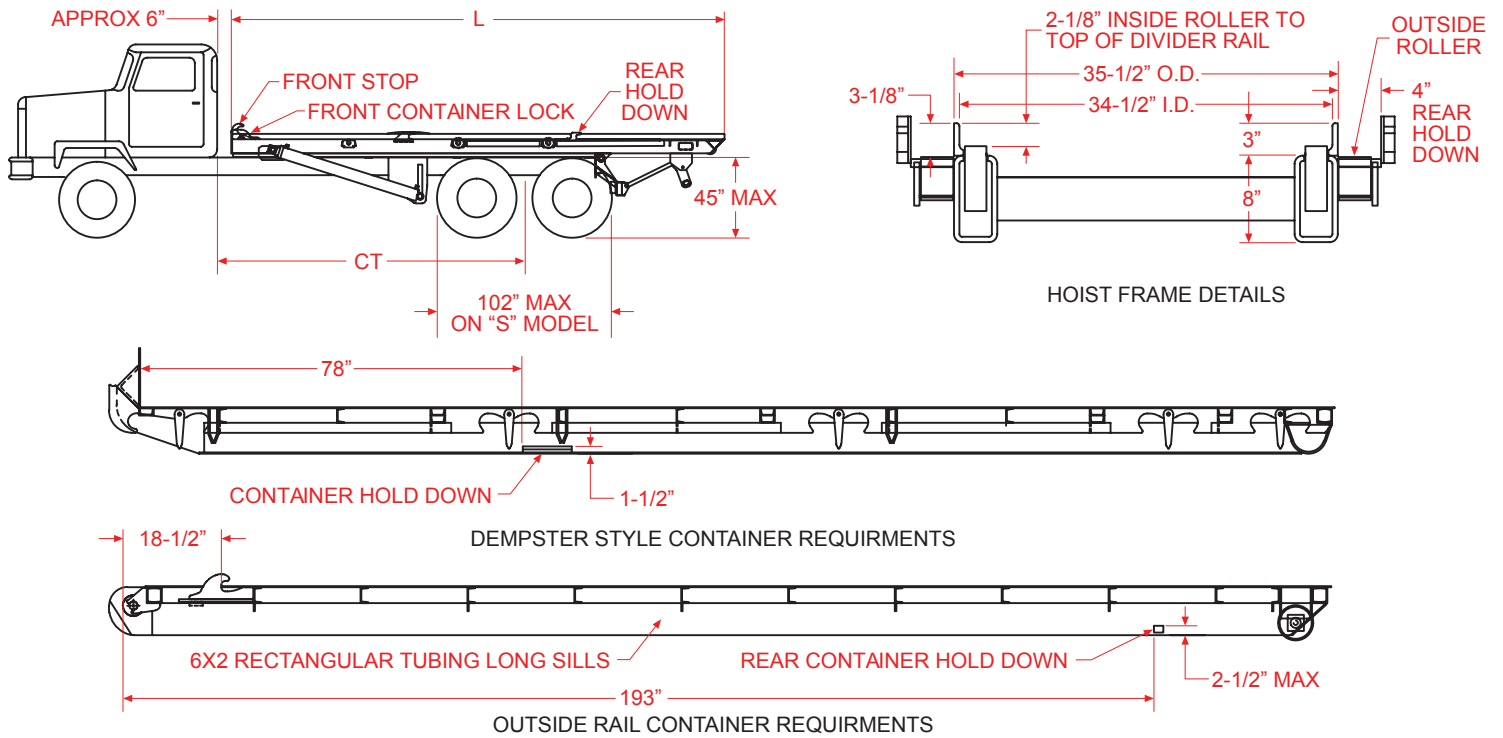

Model	Rated Cap.	CT	L	Dump Angle	Up (Sec.)*	Down (Sec.)*	On (Sec.)*	Off (Sec.)*	Lift Cylinder	Winch Cylinder	Container Length	Appx. Wgt.
IO 60174 S074.5	60,000#	174"	23' 4"	47 deg.	30	13	46	37	6" - 4 1/2" x 74 1/2" DA	7" x 3" x 81 1/2" DA	16' to 20' IR 18' to 22' OR	7900#
IO 60174 T121	60,000#	174"	23' 4"	47 deg.	43	10	46	37	6" - 5" - 4" x 121" DAT	7" x 3" x 81 1/2" DA	16' to 20' IR 18' to 22' OR	7900#
IO 60194 T121	60,000#	194"	25' 0"	47 deg.	43	10	51	42	6" - 5" - 4" x 121" DAT	7" x 3" x 91 1/2" DA	20' to 24'	8100#
IO 75174 T121	75,000#	174"	23' 4"	47 deg.	43	10	46	37	6" - 5" - 4" x 121" DAT	7" x 3" x 81 1/2" DA	16' to 20' IR 18' to 22' OR	8025#
IO 75194 T121	75,000#	194"	25' 0"	47 deg.	43	10	51	42	6" - 5" - 4" x 121" DAT	7" x 3" x 91 1/2" DA	20' to 24'	8325#
IO 60194 T083	60,000#	194"	25' 0"	47 deg.	29	15	46	40	6" - 5" x 83" DAT	7" x 3" x 91 1/2" DA	20' to 24'	7325#
IO 60194 T114	60,000#	194"	25' 0"	47 deg.	49	20	50	40	6" - 5" - 4" x 114" DAT	7" x 3" x 91 1/2" DA	20' to 24'	8225#
IO 60229 T138	60,000#	229"	28' 5"	47 deg.	60	24	72	59	6" - 5" - 4" x 138" DAT	7" x 3" x 91 1/2" DA	24' to 28'	9125#
IO 60182 S074.5	60,000#	182"	24' 0"	47 deg.	43	10	46	37	6" - 4 1/2" x 74.5" DA	7" x 3" x 81 1/2" DA	16' to 20' IR 18' to 22' OR	7925#
IO 60182 T121	60,000#	182"	24' 0"	47 deg.	43	10	46	37	6" - 5" x 4" x 121" DAT	7" x 3" x 81 1/2" DA	16' to 20' IR 18' to 22' OR	8000#

\* Cycle Times are Factory developed and controlled by PTO output, oil viscosity, human and mechanical efficiency, and may vary accordingly.

All dimensions are subject to steel and manufacturing tolerances.

CAUTION: This Equipment Should be Operated by Properly Trained Personnel. Improper Use, Misuse or Lack of Maintenance Could Cause Injury to Persons or Property. Photos used in this brochure are illustrative only. We reserve the right to make changes at any time without notice. Information contained within this literature is believed to be the most accurate available at the time of printing.

## Optional Features



"The Hooker" Securement System at Rear Hinge



Dempster Stop and Hold On



Window Screen Mounted to Tarp System Gantry